



DATE: 04 April 2016

I.T.L. (PRODUCT TESTING) LTD.

**Test Report According to
EN 301 489-1; EN 301 489-3;
EN 301 489-7; EN 301 489-17**

for

Pointer Telocation Ltd.

Equipment under test:

**2G Self-powered Smart Hub With Multi-
Sensing Device and Temperature/Humidity
Multi-Sensing Device**

**CelloTrack Nano 20, P/N: GC9770001-000; MultiSense,
P/N: 715-50100, MultiSense TH, P/N: 715-50200
CelloTrack Nano 10, P/N: GC9770002-000***

* See customer's declaration on page 5.

Tested by:



Y. Mordukhovitch

Approved by:



D. Shidlowky

This report must not be reproduced, except in full, without the written permission of I.T.L. (Product Testing) Ltd. This report relates only to items tested.

TABLE OF CONTENTS

1.	GENERAL INFORMATION -----	4
1.1	Administrative Information.....	4
1.2	Abbreviations and Symbols.....	6
1.3	List of Accreditations	7
2.	APPLICABLE DOCUMENTS -----	8
3.	TEST SITE DESCRIPTION -----	10
3.1	Location:.....	10
3.2	Shielded Room.....	10
3.3	Open Site:	10
3.4	Ground Plane:	10
3.5	Antenna Mast:	10
3.6	Turntable:	10
3.7	EMI Receiver:.....	11
3.8	E.U.T. Support:.....	11
3.9	Test Equipment:	11
4.	SUMMARY OF TEST RESULTS-----	12
5.	EQUIPMENT UNDER TEST (E.U.T.) DESCRIPTION -----	14
6.	LIST OF TEST EQUIPMENT -----	16
6.1	Immunity Tests.....	16
6.2	Emission Tests.....	17
7.	E.U.T. PERFORMANCE VERIFICATION -----	18
7.1	Mode of Operation.....	18
7.2	Monitoring of E.U.T.	18
7.3	Definition of Failure	18
8.	CONDUCTED EMISSION FROM AC MAINS-----	19
8.1	Test Specification	19
8.2	Test Procedure.....	19
8.3	Test Results	19
9.	RADIATED EMISSION-----	24
9.1	Test Specification	24
9.2	Test Procedure.....	24
9.3	Test Results	24
10.	VOLTAGE FLUCTUATIONS ON POWER LINES -----	26
10.1	Test Specification	26
10.2	Test Procedure.....	26
10.3	Test Results	26
11.	IMMUNITY TO ELECTROSTATIC DISCHARGE -----	28
11.1	Test Specification	28
11.2	Test Procedure.....	28
11.3	Test Results	28
12.	IMMUNITY TO RADIATED FIELD -----	40
12.1	Test Specification	40
12.2	Test Procedure.....	40
12.3	Test Results	40
13.	IMMUNITY TO ELECTRICAL FAST TRANSIENT / BURST -----	42
13.1	Test Specification	42
13.2	Test Procedure.....	42
13.3	Test Results	42



14.	IMMUNITY TO CONDUCTIVE SURGES -----	44
14.1	Test Specification	44
14.2	Test Procedure.....	44
14.3	Test Results	44
15.	IMMUNITY TO CONDUCTED DISTURBANCES -----	46
15.1	Test Specification	46
15.2	Test Procedure.....	46
15.3	Test Results	46
16.	VOLTAGE DIPS AND SHORT INTERRUPTIONS -----	48
16.1	Test Specification	48
16.2	Test Procedure EN 301 489-1	48
16.3	Test Procedure EN 301 489-3	48
16.4	Test Results	48
17.	SET UP PHOTOGRAPHS -----	49
18.	SIGNATURES OF THE E.U.T'S TEST ENGINEERS -----	56
19.	APPENDIX A - CORRECTION FACTORS -----	58
19.1	Correction factors for CABLE	58
19.2	Correction factors for Biconical antenna	59
19.3	Correction factors for Log Periodic ANTENNA	60
20.	APPENDIX B - MEASUREMENT UNCERTAINTY -----	61



1. General Information

1.1 Administrative Information

Manufacturer:	Pointer Telocation Ltd.
Manufacturer's Address:	14 Hamelacha St., Rosh Ha'ayin, 48091 Israel Tel: +972-3-572-3111 Fax: +972-73-262-2344
Manufacturer's Representative:	Refael Yakobov
Equipment Under Test (E.U.T):	2G Self-powered Smart Hub With Multi-Sensing Device and Temperature/Humidity Multi-Sensing Device
Equipment Model No.:	CelloTrack Nano 20, P/N: GC9770001-000; MultiSense, P/N: 715-50100, MultiSense TH, P/N: 715-50200 CelloTrack Nano 10, P/N GC9770002-000*
Equipment Serial No.:	982966, 48.1A.84.00.06.E8, 48.1A.84.00.06.61
Date of Receipt of E.U.T:	03.01.16
Start of Test:	03.01.16
End of Test:	05.01.16
Test Laboratory Location:	I.T.L (Product Testing) Ltd. 1 Batsheva St., Lod ISRAEL 7120101
Test Specifications:	EN 301 489-1 V1.9.2: 2011 EN 301 489-3 V1.6.1: 2013 EN 301 489-7 V1.3.1: 2005 EN 301 489-17 V2.2.1: 2012

* See customer's declaration on following page.



POINTER

DECLARATION

Date: 14/2/2016

I HEREBY DECLARE THE FOLLOWING REGARDING THE BELOW MODELS:

#	Product name	P/N
1	CelloTrack Nano 20	GC9770001-000
2	CelloTrack Nano 20 3G	GC9771004-000
3	CelloTrack Nano 10	GC9770002-000
4	CelloTrack Nano 10 3G	GC9771003-000

All of the above models use the same PCB.

These models are all identical except:

1. That P/N GC9770001-000 has the Cinterion BGS2-W 2G GSM cellular modem while P/N GC9771004-000 has the Cinterion EHS6A 3G cellular modem.
2. That in P/N GC9770002-000 and P/N GC9771003-000 the 2.4GHz transmitter is deactivated by firmware.
3. That in both P/N GC9770001-000 and P/N GC9770002-000 have the Cinterion BGS2-W 2G GSM cellular modem while P/N GC9771003-000 and P/N GC9771004-000 both have the Cinterion EHS6A 3G cellular modem.

Please relate to them (from an EMC/RADIO point of view) as the same product.

Signature Igor Rogov
Igor Rogov 16-02-2016
VP R&D VP R&D
Pointer Telocation Inc.

1.2 Abbreviations and Symbols

The following abbreviations and symbols are applicable to this test report:

A/m	ampere per meter
AC	alternating current
AM	amplitude modulation
AMN	Artificial Mains Network
ARA	Antenna Research Associates
Aux	auxiliary
Avg	average
CDN	coupling-decoupling network
cm	centimeter
dB	decibel
dBm	decibel referred to one milliwatt
db μ V	decibel referred to one microvolt
db μ V/m	decibel referred to one microvolt per meter
DC	direct current
EFT/B	electrical fast transient/burst
EMC	electromagnetic compatibility
ESD	electrostatic discharge
E.U.T.	equipment under test
GHz	gigahertz
HP	Hewlett Packard
Hz	Hertz
kHz	kilohertz
kV	kilovolt
LED	light emitting diode
LISN	line impedance stabilization network
m	meter
mHn	millihenry
MHz	megahertz
msec	millisecond
N/A	not applicable
per	period
QP	quasi-peak
PC	personal computer
RF	radio frequency
RE	radiated emission
sec	second
V	volt
V/m	volt per meter
VRMS	volts root mean square



1.3 List of Accreditations

The EMC laboratory of I.T.L. is accredited by the following bodies:

1. The American Association for Laboratory Accreditation (A2LA) (U.S.A.), Certificate No. 1152.01.
2. FCC Designation Number IL1005.
3. The Israel Ministry of the Environment (Israel), Registration No. 1104/01.
4. The Voluntary Control Council for Interference by Information Technology Equipment (VCCI) (Japan), Registration Numbers: C-3006, R-2729, T-1877, G-245.
5. Industry Canada (Canada), IC File No.: 46405-4025; Sites No. IC 4025A-1; 4025A-2.

I.T.L. Product Testing Ltd. is accredited by the American Association for Laboratory Accreditation (A2LA) and the results shown in this test report have been determined in accordance with I.T.L.'s terms of accreditation unless stated otherwise in the report.

2. Applicable Documents

- | | | |
|-----|--------------------------------------------|-----------------------------------------------------------------------------------------------------------------------------------------------------------------------------------------------------------------------------------------------------------------------------------------------------------|
| 2.1 | R&TTE Directive: 1999 | <i>DIRECTIVE 1999/5/EC OF THE EUROPEAN PARLIAMENT AND OF THE COUNCIL of 9 March 1999 on radio equipment and telecommunications terminal equipment and the mutual recognition of their conformity</i> |
| 2.2 | EN 301 489-1 V1.9.2: 2011 | <i>Electromagnetic compatibility and Radio spectrum Matters (ERM); ElectroMagnetic Compatibility (EMC) standard for radio equipment and services; Part 1: Common technical requirements</i> |
| 2.3 | EN 301 489-3 V1.6.1: 2013 | <i>Electromagnetic compatibility and Radio spectrum Matters (ERM); ElectroMagnetic Compatibility (EMC) standard for radio equipment and services; Part 3: Specific conditions for Short-Range Devices (SRD) operating on frequencies between 9 kHz and 246 GHz</i> |
| 2.4 | EN 301 489-7 V1.3.1: 2005 | <i>Electromagnetic compatibility and Radio spectrum Matters (ERM); ElectroMagnetic Compatibility (EMC) standard for radio equipment and services; Part 7: Specific conditions for mobile and portable radio and ancillary equipment of digital cellular radio telecommunication systems (GSM and DCS)</i> |
| 2.5 | EN 301 489-17 V2.2.1: 2012 | <i>Electromagnetic compatibility and Radio spectrum Matters (ERM); ElectroMagnetic Compatibility (EMC) standard for radio equipment and services; Part 17: Specific conditions for Broadband Data Transmission Systems</i> |
| 2.6 | EN 55022: 2006 + Amendment A1: 2007 | <i>Limits and Methods of Measurement of Radio Disturbance Characteristics of Information Technology Equipment.</i> |
| 2.7 | EN 61000-3-2: 2014 | <i>Electromagnetic Compatibility (EMC), Part 3: Limits Section 2-Limits for Harmonic Currents Emissions (equipment input current ≤ 16 A per phase)</i> |
| 2.8 | EN 61000-3-3: 2013 | <i>Electromagnetic Compatibility (EMC), Part 3: Limits Section 3: Limitation of Voltage Fluctuations and Flicker in low-voltage supply systems for equipment with rated current ≤ 16 A</i> |
| 2.9 | EN 61000-4-2: 2009 | <i>Electromagnetic Compatibility (EMC), Part 4: Testing and Measurement Techniques; Section 2: Electrostatic discharge immunity test: Basic EMC publication.</i> |



Applicable Documents (cont'd.)

- | | | |
|------|-----------------------------------------------------------|------------------------------------------------------------------------------------------------------------------------------------------------------------------------------|
| 2.10 | EN 61000-4-3: 2006 + Amendments A1: 2008; A2: 2010 | <i>Electromagnetic Compatibility (EMC), Part 4: Testing and Measurement Techniques; Section 3: Radiated, radio frequency, electromagnetic field immunity test.</i> |
| 2.11 | EN 61000-4-4: 2004 + Amendment A1: 2010 | <i>Electromagnetic compatibility (EMC), Part 4. Testing and measurement techniques; Electrical fast transient /burst immunity test, Basic EMC Publication.</i> |
| 2.12 | EN 61000-4-5: 2006 | <i>Electromagnetic Compatibility (EMC), Part 4: Testing and Measurement Techniques; Section 5: Surge immunity test.</i> |
| 2.13 | EN 61000-4-6: 2009 | <i>Electromagnetic Compatibility (EMC), Part 4: Testing and Measurement Techniques; Section 6: Conducted disturbances induced by radio-frequency fields.</i> |
| 2.12 | EN 61000-4-11: 2004 | <i>Electromagnetic Compatibility (EMC) Part 4: Testing and Measurement Techniques; Section 11: Voltage dips, short interruptions and voltage variations; Immunity tests.</i> |

3. Test Site Description

3.1 Location:

The Electromagnetic Compatibility Test Facility of I.T.L. (Product testing) Ltd. Is located at Telrad Industrial Park, Lod, 7120101 Israel.

Telephone: +972-8-9153100

Fax: +972-8-9153101

3.2 Shielded Room

A Modular Shielded Room, Type 20 SpaceSaver, manufactured by ETS, consisting of a Main Room and a Control Room.

The dimensions of the Main Room are: length: 7.0 m, width: 3.0 m, height: 3.0 m.

The shielding performance is:

magnetic field: 60 dB at 10 kHz rising linearly to 100 dB at 100 kHz,

electric field: better than 110 dB between 50 MHz and 1 GHz,

plane wave: 110 dB between 50 MHz and 1 GHz.

All the power lines entering the shielded room are filtered.

3.3 Open Site:

The OATS is located on a one floor-building roof. The OATS consists of 3 meter and 10 meter ranges, using a 21.5m X 8.5m solid metal ground plane, a remote controlled turntable and an antenna mast.

3.4 Ground Plane:

The ground plane is made from steel plates, which are welded continuously together. The Ground plane is lies and welded on welded steel construction with vias to allow for water drainage. All the power, control, and signal lines to the turntable and the 3 m and 10m antenna mast outlets are routed in shielded conduits under the plane to the control building.

3.5 Antenna Mast:

ETS model 2070-2. The antenna position and polarization are remote controlled via Fiber Optical Link using ETS/EMCO Dual Controller Type 2090. The antenna position is adjustable between 1-4 meters. Pressurized air is used to power changing the polarity of the antenna.

3.6 Turntable:

ETS model 2087 series. The position of the turntable is remote-controlled via Fiber Optic Link, using ETS/EMCO Dual Controller Type 2090. The turntable is mounted in a pit and its surface is flush with the Open Site Ground Plane. Brushes near the periphery of the turntable ensure good conductive connection to the ground plane. The Turntable maximum load is 1250 Kg.



3.7 EMI Receiver:

Type 8542E, manufactured by HP, being in full compliance with CISPR 16 requirements.

3.8 E.U.T. Support:

Table mounted E.U.T.s are supported during testing on 80 cm high all plastic table.

3.9 Test Equipment:

See details in Section 6.

4. Summary of Test Results

Test	Results
<p>Conducted Emissions From AC Mains EN 55022: 2006 + Amendment A1: 2007, Class B</p>	<p>Passed</p> <p>The margin between the emission levels and the specification limit was, in the worst case, 15.0 dB for the phase line at 0.49 MHz and 14.4 dB for the neutral line at 0.49 MHz.</p>
<p>Radiated Emissions EN 55022: 2006 + Amendment A1: 2007, Class B</p>	<p>Passed</p> <p>The margin between the emission level and the specification limit was 12.9 dB in the worst case at the frequency of 125.86 MHz, vertical polarization.</p>
<p>Harmonic Emissions EN 61000-3-2: 2014</p>	<p>N/A</p> <p>According to Clause 7.</p>
<p>Voltage Fluctuations EN 61000-3-3: 2013</p>	<p>Passed</p>
<p>ESD EN 61000-4-2: 2009 Air Discharge, 8kV Contact Discharge, 4kV</p>	<p>Passed</p>
<p>Radiated Immunity EN 61000-4-3: 2006 + Amendments A1: 2008; A2: 2010 (80-1000; 1400-2700 MHz) 3 V/m, 80% A.M. by 1kHz</p>	<p>Passed</p>



Summary of Test Results (cont'd.)

Test	Results
<p>EFT/B EN 61000-4-4: 2004 + Amendment A1: 2010 1kV Power lines</p>	Passed
<p>Conductive Surges EN 61000-4-5: 2006 Differential mode; 1kV</p>	Passed
<p>Conducted Disturbances (0.15-80 MHz) EN 61000-4-6: 2009 3 VRMS, 80% A.M. by 1kHz</p>	Passed
<p>Voltage Dips and Short Interruptions EN 301 489-1: EN 61000-4-11: 2004 Voltage reduction: 1) 100%, 2) 100%, 3) 30%, 4) 100% Duration: 1) 0.5 cycle, 2) 1 cycle, 3) 25 cycles 4) 250 cycles EN 301 489-3: EN 61000-4-11: 2004 Voltage reduction: 1) 30%, 2) 60%, 3) >95% Duration: 1) 10 msec., 2) 100 msec., 3) 5000 msec.</p>	Passed

5. Equipment Under Test (E.U.T.) Description

CelloTrack Nano 20, P/N: GC9770001-000:

Self-powered Smart hub for Asset & Cargo Management IoT applications supporting 2G cellular communication, GNSS, short range RF and wide sensing capabilities.

MultiSense, P/N: 715-50100:

All-in-one multi-sensing device for cargo and cold chain monitoring, supporting short range RF communication.

MultiSense TH, P/N: 715-50200:

All-in-one multi-sensing device including humidity sensor for cargo and cold chain monitoring, supporting short range RF communication.

List of ancillary and/or support equipment provided by the applicant

Description	Manufacturer	Model/Part Number	Serial Number
Pointer server			
AUX Laptop	Lenovo	Type 2518-4PG	ID 25184PG
AUX adapter	Lenovo	92P1158	11S9P1158Z1ZD2H79V51

Input/Output Ports:

Port No.	Name	Type*	Cable Max. >3m	Cable Shielded	Comments
0	Enclosure	N/E	—	—	None
1	AC power port	AC	-	-	CelloTrack Nano 20

*Note: AC = AC Power Port DC = DC Power Port N/E = Non-Electrical
I/O = Signal Input or Output Port (Not Involved in Process Control)
TP = Telecommunication Ports

EUT Internal Operating Frequencies:

Frequency (MHz)	Description	Frequency (MHz)	Description
16.0	Bluetooth clock		
0,032768	clock		
32.0	CPU		



Power Interface

Mode No.	Voltage (V)	Current (A)	Power (W)	Frequency (DC/AC-Hz)	Phases (No.)	Comments
Rated						
1	100-240	0.3	72	50-60	1	CelloTrack Nano 20
2	3			DC		MultiSense
3	3			DC		MultiSense TH
Supplementary information:						

6. List of Test Equipment

6.1 Immunity Tests

Equipment indicated below by an “X” used in Tests IEC 61000-4:-2,-3,-4,-5,-6, -11.

Test equipment calibration is in accordance with ITL Q.A. Procedure PM 110, "Calibration Control Procedure", which complies with ISO/IEC Guide 17025.

Instrument	Manuf.	Model	Serial No.	Used in Test IEC 61000-4:					
				-2	-3	-4	-5	-6	-11
Transient Generator	KeyTek	CEMASTER	9612436			X			
ESD Simulator	KIKUSUI	KES4021A	UG002517	X					
Isotropic Field Probe	AR	FP-2000	19419		X				
RF Amplifier	AR	100W1000M1	19842		X				
Isotropic Field Monitor	AR	FM-2000	19719		X				
Biconilog Antenna	EMCO	3142B	1078		X				
Horn Antenna	EMCO	3115	29845		X				
RF Amplifier	OPHIR	5303081	1002		X				
RF Amplifier	IFI	SMX100	1194-4537		X			X	
Signal Generator	HP	8657A	3430U2142		X			X	
BulkF Current Probe	FCC	F-120-9	105					X	
CDN	FCC	FCC-801-M3-16A	9962					X	
Transient Wave- form Monitor	CDI	TWM-100	3233						
Phase Control Amplifier	CDI	PCA-1000	3217						
Single Phase Isolated Backfilter	CDI	CDI-1kVA	3221						
Surge Generator	CDI	CDI-1000i	3153						
Surge Generator	EM TEST	UCS 500-M	1198-45				X		
AC Power Source	EM TEST	UCS 500-M	1198-45						X



6.2 Emission Tests

The equipment indicated below by an “X” was used for testing Conducted Emission Power Lines(CEP), Conducted Emission Telecom(CET), Radiated Emission (RE), and IEC 61000-3-2;3

Test equipment calibration is in accordance with ITL Q.A. Procedure PM 110 "Calibration Control Procedure", which complies with ISO/IEC Guide 17025.

Instrument	Manufacturer	Model	Serial No.	Used in Tests				
				CEP	CET	RE	-2	-3
ISN	T3SEQ	ISN T8-Cat 6	28749					
ISN	T3SEQ	ISN T800	27986					
LISN	Fischer	FCC-LISN-2A	127	X				
Transient Limiter	HP	11947A	3107A03041	X				
Current Probe	FCC	F51	163					
EMI Receiver	Rohde & Schwarz	ESC17	100724	X				
EMI Receiver	HP	8542E	3906A00276			X		
EMI Receiver Filter	HP	85420E	3705A00248			X		
RF Amplifier	HP	83006A	3104A00589			X		
RF Amplifier	MITEQ	50-8P	AFSX4			X		
EMC Analyzer	HP	HP8593	3536A00120			X		
Biconical Antenna	EMCO	3104	2606			X		
Log Periodic Antenna	EMCO	3146	9505-4081			X		
Horn Antenna	EMCO	3115	29845			X		
Antenna Mast	ETS	2070-2	9608-1497			X		
Turntable	ETS	2087	-			X		
Mast & Table Controller	ETS/EMCO	2090	9608-1456			X		
Power Analysis System	EM Test	DPA 500	0501/09				X	X
AC Power Source	EM Test	ACS 500	1101/01				X	X

7. E.U.T. Performance Verification

7.1 Mode of Operation

The E.U.T.s were operated in regular mode with 10s period between Bluetooth transmissions between the MultiSense and MultiSense TH to the CelloTrack Nano 20 and 4s between cellular transmissions between the CelloTrack Nano 20 and the Pointer Telocation server. The auxiliary laptop communicated with the Pointer Telocation Server via W-Fi connection to the internet.

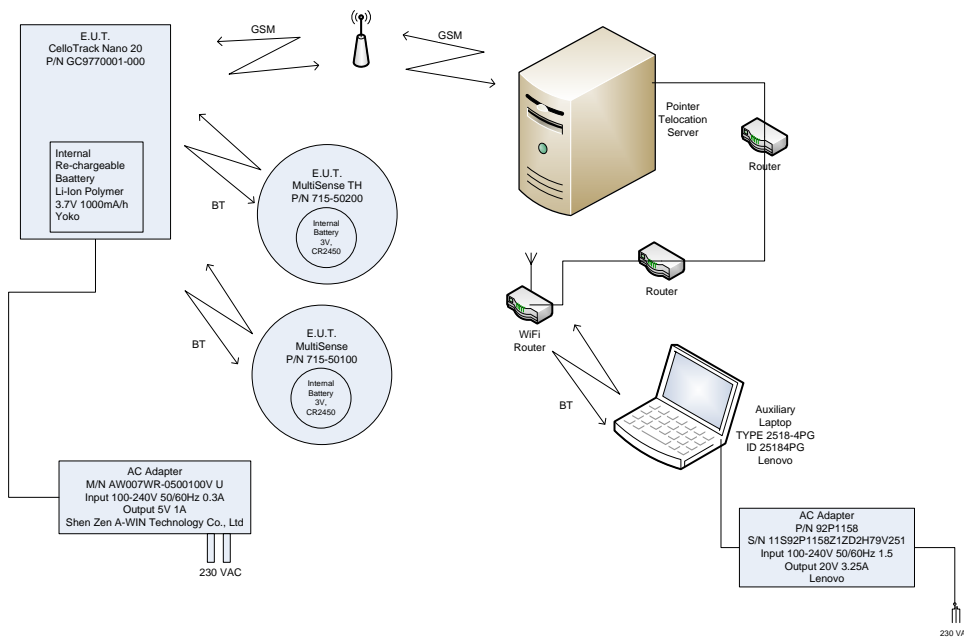

Figure 1. Test Set-up

7.2 Monitoring of E.U.T.

The AUX laptop screen was observed during and after the immunity tests. On the screen the “Communication center” program “window” with receiving results of the Bluetooth transmissions and cellular transmissions was observed.

7.3 Definition of Failure

Any cessation of the communications was regarded as a failure.

8. Conducted Emission From AC Mains

8.1 Test Specification

0.15-30 MHz, EN 55022: 2006 + Amendment A1: 2007, CLASS B

8.2 Test Procedure

The E.U.T operation mode and test set-up are as described in Section 7.1. In order to minimize background noise interference, the conducted emission testing was performed inside a shielded room (see Section 3), with the E.U.T (table-top) placed on a 0.4 meter high wooden table. Floor-standing E.U.T. was placed on the horizontal ground plane.

The E.U.T was powered via 50 Ohm / 50 μ Hn Artificial Mains Network (AMN) on the phase and neutral lines. The AMN's were grounded to the shielded room ground plane (floor), and were kept at least 0.8 meters from the nearest boundary of the E.U.T

The center of the E.U.T.'s AC cable was folded back and forth, in order to form a bundle less than 0.40 meters and a total cable length of 1 meter.

The effect of varying the position of the cables was investigated to find the configuration that produces maximum emission. The configuration tested is shown in the photograph, *Figure 23. Conducted Emission From AC Mains Test.*

The emission voltages at the AMN's outputs were measured using a computerized receiver, complying with CISPR 16 requirements. The specification limits are pre-loaded to the receiver and are displayed on the receiver's spectrum display.

A frequency scan between 0.15 and 30 MHz was performed at 9 kHz I.F. band width, using peak detection.

The spectral components having the highest level on each line were measured using a quasi-peak and average detector.

8.3 Test Results

The E.U.T complies with the EN 55022: 2006 + Amendment A1: 2007, Class B specification requirements.

The margin between the emission levels and the specification limit is, in the worst case, 15.0 dB for the phase line at 0.49 MHz and 14.4 dB at 0.49 MHz for the neutral line.

The details of the highest emissions are given in *Figure 2 to Figure 5.*

Conducted Emission

E.U.T Description: 2G Self-powered Smart Hub With Multi-Sensing Device and Temperature/Humidity Multi-Sensing Device
 Type: CelloTrack Nano 20, P/N: GC9770001-000; MultiSense, P/N: 715-50100, MultiSense TH, P/N: 715-50200
 Serial Number: 982966, 48.1A.84.00.06.E8, 48.1A.84.00.06.61

Specification: EN 55022: 2006 + Amendment A1: 2007, Class B
 Lead: Phase
 Detectors: Quasi-peak, Average

EDIT PEAK LIST (Final Measurement Results)				
Trace1:		CE22BQP		
Trace2:		CE22BAP		
Trace3:		---		
	TRACE	FREQUENCY	LEVEL dBµV	DELTA LIMIT dB
1	Quasi Peak	194 kHz	36.70	-27.15
2	Average	382 kHz	28.17	-20.06
1	Quasi Peak	486 kHz	38.31	-17.92
2	Average	490 kHz	31.18	-14.98
2	Average	670 kHz	22.60	-23.39
2	Average	786 kHz	27.23	-18.76
1	Quasi Peak	798 kHz	32.30	-23.69
2	Average	882 kHz	26.21	-19.78
1	Quasi Peak	886 kHz	32.91	-23.08
1	Quasi Peak	1.35 MHz	29.51	-26.48
2	Average	1.426 MHz	23.26	-22.74
2	Average	1.994 MHz	22.74	-23.25
1	Quasi Peak	1.998 MHz	28.56	-27.43
2	Average	2.002 MHz	22.56	-23.43
1	Quasi Peak	2.01 MHz	28.49	-27.50
1	Quasi Peak	2.586 MHz	27.94	-28.05
2	Average	2.638 MHz	21.72	-24.27
2	Average	3.198 MHz	22.00	-23.99
1	Quasi Peak	3.206 MHz	27.22	-28.78
1	Quasi Peak	4.398 MHz	26.05	-29.94

Date: 4.JAN.2016 12:11:15

Figure 2. Detectors: Quasi-peak, Average

Note: DELTA LIMIT refer to the test results obtained minus specified requirement; thus a positive number indicates failure, and a negative result indicates that the product passes the test.

Conducted Emission

E.U.T Description: 2G Self-powered Smart Hub With Multi-Sensing Device and Temperature/Humidity Multi-Sensing Device
 Type: CelloTrack Nano 20, P/N: GC9770001-000; MultiSense, P/N: 715-50100, MultiSense TH, P/N: 715-50200
 Serial Number: 982966, 48.1A.84.00.06.E8, 48.1A.84.00.06.61

Specification: EN 55022: 2006 + Amendment A1: 2007, Class B
 Lead: Phase
 Detectors: Quasi-peak, Average

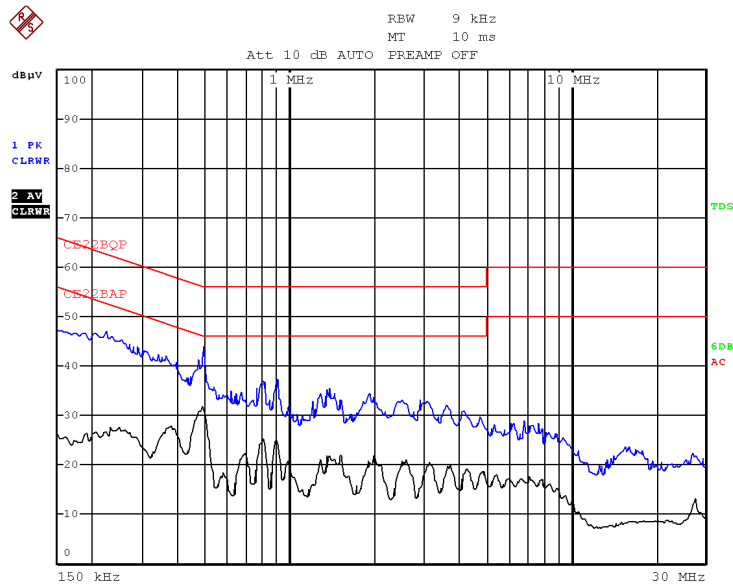

Date: 5.JAN.2016 10:53:01

Figure 3. Detectors: Quasi-peak, Average

Conducted Emission

E.U.T Description: 2G Self-powered Smart Hub With Multi-Sensing Device and Temperature/Humidity Multi-Sensing Device
 Type: CelloTrack Nano 20, P/N: GC9770001-000; MultiSense, P/N: 715-50100, MultiSense TH, P/N: 715-50200
 Serial Number: 982966, 48.1A.84.00.06.E8, 48.1A.84.00.06.61

Specification: EN 55022: 2006 + Amendment A1: 2007, Class B

Lead: Neutral

Detectors: Quasi-peak, Average

EDIT PEAK LIST (Final Measurement Results)				
Trace1: CE22BQP				
Trace2: CE22BAP				
Trace3: ---				
TRACE	FREQUENCY	LEVEL dBμV	DELTA	LIMIT dB
1 Quasi Peak	154 kHz	35.44	-30.34	
1 Quasi Peak	374 kHz	38.43	-19.97	
2 Average	374 kHz	23.52	-24.88	
2 Average	482 kHz	26.50	-19.80	
1 Quasi Peak	486 kHz	41.83	-14.39	
2 Average	770 kHz	24.82	-21.17	
1 Quasi Peak	786 kHz	38.49	-17.50	
1 Quasi Peak	882 kHz	38.66	-17.33	
2 Average	886 kHz	24.15	-21.84	
2 Average	1.49 MHz	23.69	-22.30	
2 Average	1.99 MHz	23.38	-22.61	
2 Average	2.01 MHz	23.02	-22.97	
2 Average	2.514 MHz	22.15	-23.84	
2 Average	3.198 MHz	22.83	-23.16	
2 Average	3.734 MHz	22.24	-23.75	
1 Quasi Peak	4.362 MHz	29.44	-26.55	
1 Quasi Peak	4.374 MHz	29.31	-26.68	
1 Quasi Peak	4.55 MHz	26.07	-29.92	
1 Quasi Peak	4.558 MHz	26.28	-29.72	
1 Quasi Peak	4.586 MHz	25.87	-30.12	

Date: 4.JAN.2016 12:17:33

Figure 4. Detectors: Quasi-peak, Average

Note: DELTA LIMIT refer to the test results obtained minus specified requirement; thus a positive number indicates failure, and a negative result indicates that the product passes the test.

Conducted Emission

E.U.T Description: 2G Self-powered Smart Hub With Multi-Sensing Device and Temperature/Humidity Multi-Sensing Device
 Type: CelloTrack Nano 20, P/N: GC9770001-000; MultiSense, P/N: 715-50100, MultiSense TH, P/N: 715-50200
 Serial Number: 982966, 48.1A.84.00.06.E8, 48.1A.84.00.06.61

Specification: EN 55022: 2006 + Amendment A1: 2007, Class B
 Lead: Neutral
 Detectors: Quasi-peak, Average

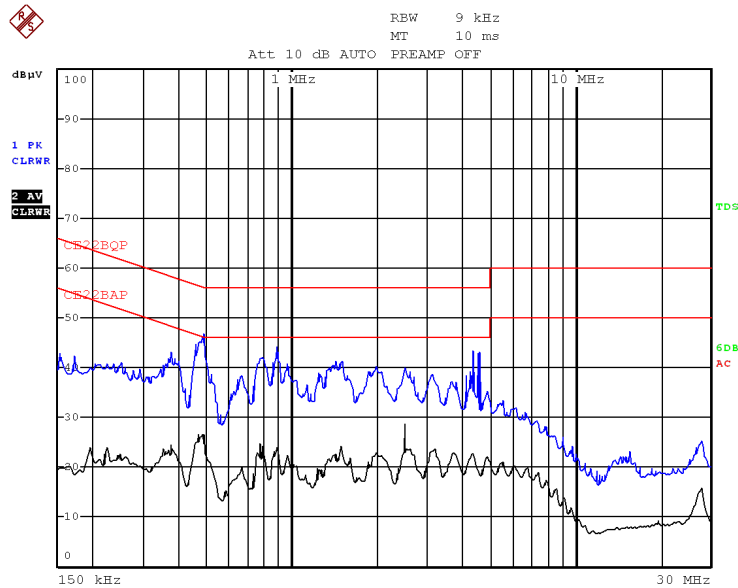

Date: 4.JAN.2016 12:15:29

Figure 5 Detectors: Quasi-peak, Average

9. Radiated Emission

9.1 Test Specification

30-1000 MHz, EN 55022: 2006 + Amendment A1: 2007, CLASS B

9.2 Test Procedure

The E.U.T operation mode and test set-up are as described in section 7.1.

A preliminary measurement to characterize the E.U.T was performed inside the shielded room. The preliminary measurements produced a list of the highest emissions. The E.U.T was then transferred to the open site, and placed on a remote-controlled turntable. For table-top products, the E.U.T was placed on a non-metallic table, 0.8 meters above the ground. For floor-standing products, the E.U.T. was placed directly on the horizontal ground plane, but was separated from metallic contact with the ground plane by up to 15 cm of insulation. The effect of varying the position of the cables was investigated to find the configuration that produces maximum emission.. The configuration tested is shown in the photograph *Figure 24. Radiated Emission Test*.

The E.U.T. highest frequency source or used frequency is 32 MHz.

The frequency range 30-1000 MHz was scanned, and the list of the highest emissions was verified and updated accordingly.

The emissions were measured using a computerized EMI receiver complying with CISPR 16 requirements. The specification limits and applicable correction factors are pre-loaded to the receiver.

The readings were maximized by adjusting the antenna height between 1-4 meters, the turntable azimuth between 0-360°, and the antenna polarization.

Verification of the E.U.T emissions was based on the following methods:

- Turning the E.U.T on and off.

- Using a frequency span less than 10 MHz.

- Observation of the signal level during turntable rotation. Background noise is not affected by the rotation of the E.U.T.

The emissions were measured at a distance of 3 meters on the OATS.

9.3 Test Results

The E.U.T met the requirements of the EN 55022: 2006 + Amendment A1: 2007, CLASS B specification.

The margin between the emission level and the specification limit is 12.9 dB in the worst case at the frequency of 125.86 MHz, vertical polarization.

The details of the highest emissions are given in *Figure 6*.



Radiated Emission

E.U.T Description: 2G Self-powered Smart Hub With Multi-Sensing Device and Temperature/Humidity Multi-Sensing Device
 Type: CelloTrack Nano 20, P/N: GC9770001-000; MultiSense, P/N: 715-50100, MultiSense TH, P/N: 715-50200
 Serial Number: 982966, 48.1A.84.00.06.E8, 48.1A.84.00.06.61

Specification: EN 55022: 2006 + Amendment A1: 2007, Class **B**

Antenna Polarization: Horizontal/Vertical Frequency range: 30 MHz to 1000 MHz
 Antenna: 3 meters distance Detectors: Peak, Quasi-peak

Frequency (MHz)	Antenna Polarization		Azimuth (Degrees)	Antenna Height (cm)	Peak Amp (dB μ V/m)	QP Amp (dB μ V/m)	Limit (dB μ V/m)	Margin (dB)
	Hor.	Ver.						
70.02	X		0.0	100.0	27.2	21.5	40.5	-19.0
80.00	X		0.0	100.0	26.2	20.3	40.5	-20.2
125.19	X		204.6	100.0	31.2	21.8	40.5	-18.7
480.00	X		74.1	109.2	27.1	22.6	47.5	-24.9
123.69		X	117.4	100.0	33.6	26.5	40.5	-14.0
125.86		X	0.0	100.0	33.6	27.6	40.5	-12.9
288.00		X	0.0	100.0	25.6	19.7	47.5	-27.8

Figure 6. Radiated Emission. Antenna Polarization: HORIZONTAL/VERTICAL. Detectors: Peak, Quasi-peak

Note: Margin refers to the test results obtained minus specified requirement; thus a positive number indicates failure, and a negative result indicates that the product passes the test.



10. Voltage Fluctuations on Power Lines

10.1 Test Specification

EN 61000-3-3: 2013

10.2 Test Procedure

The test was performed at 230 VAC/ 50 Hz. The mode of operation was as described in section 7.

The following parameters were measured:

Pst (Short Term Flicker)

Plt (Long Term Flicker)

Dc (Relative Steady State Voltage Change)

Dmax (Maximum Relative Voltage Change)

D(t) (Relative Voltage Change Characteristic)

For Pst measurement, 10 minutes observation was used.

For Plt measurement, 120 minutes observation was used.

The test set-up utilized for this specification is shown in the photograph, *Figure 25 Voltage Fluctuations Test*.

10.3 Test Results

The E.U.T met the requirements of EN 61000-3-3: 2013.

Additional details are given in *Figure 7*.



Voltage Fluctuations on Power Lines

E.U.T Description 2G Self-powered Smart Hub
Type CelloTrack Nano 20, P/N: GC9770001-000
Serial Number: 982966

Specification: EN 61000-3-3: 2013

Parameter	Result	Specification
Pst	0.028	<1
Plt	0.028	< 0.65
Dc (%)	0.004%	<3%
Dmax (%)	0.079%	<4%
D(t) (%)	0.000%	<3%

Figure 7. Voltage Fluctuations

11. Immunity to Electrostatic Discharge

11.1 Test Specification

EN 61000-4-2: 2009

11.2 Test Procedure

In the case of tabletop equipment, the E.U.T. was set up on a wooden table 0.8m high on an insulating support 0.5 mm thick above the reference ground plane. In the case of floor-standing equipment, the EUT and cables were set up on an insulating support 0.1m above the reference plane. The test setup is illustrated in the photograph, *Figure 26. Immunity to Electrostatic Discharge Test.*

Photographs in *Figure 8 to Figure 10* show the locations of test points.

11.2.1 Air Discharge

Potentials of 2, 4 and 8 kV were applied near each applicable test point. At places where discharge occurred, the potential was applied twenty times; ten times negative and ten times positive. The E.U.T.'s performance during the test was verified as detailed in Section 7.

11.2.2 Contact Discharge

Potentials of 2 and 4 kV were applied to each applicable test point. In places where discharge occurred, the potential was then applied twenty times; ten negative and ten positive discharges. The E.U.T.'s performance during the test was verified as detailed in Section 7.

11.2.3 Indirect Discharge (vertical and horizontal coupling plane)

Potentials of 2 and 4 kV were applied to the center of the vertical edge of the coupling plane at a distance of 0.1 meters from the outer casing of the E.U.T. to each applicable test point.

The potential was applied 10 times for each polarity, to each location of the coupling plane. All four faces of the E.U.T. were completely illuminated.

An ESD of the same characteristics as for the vertical coupling plane was applied to the horizontal coupling plane, at each side of the E.U.T., at a distance of 0.1 meter from it's outer casing.

Additional details are shown in Figure 5 of EN 61000-4-2: 2009.

The E.U.T.'s performance during the test was verified as detailed in Section 7.

11.3 Test Results

The E.U.T met the requirements of specification EN 61000-4-2: 2009.

Immunity to Electrostatic Discharge

E.U.T Description 2G Self-powered Smart Hub
Type CelloTrack Nano 20, P/N: GC9770001-000
Serial Number: 982966

Specification: EN 61000-4-2: 2009

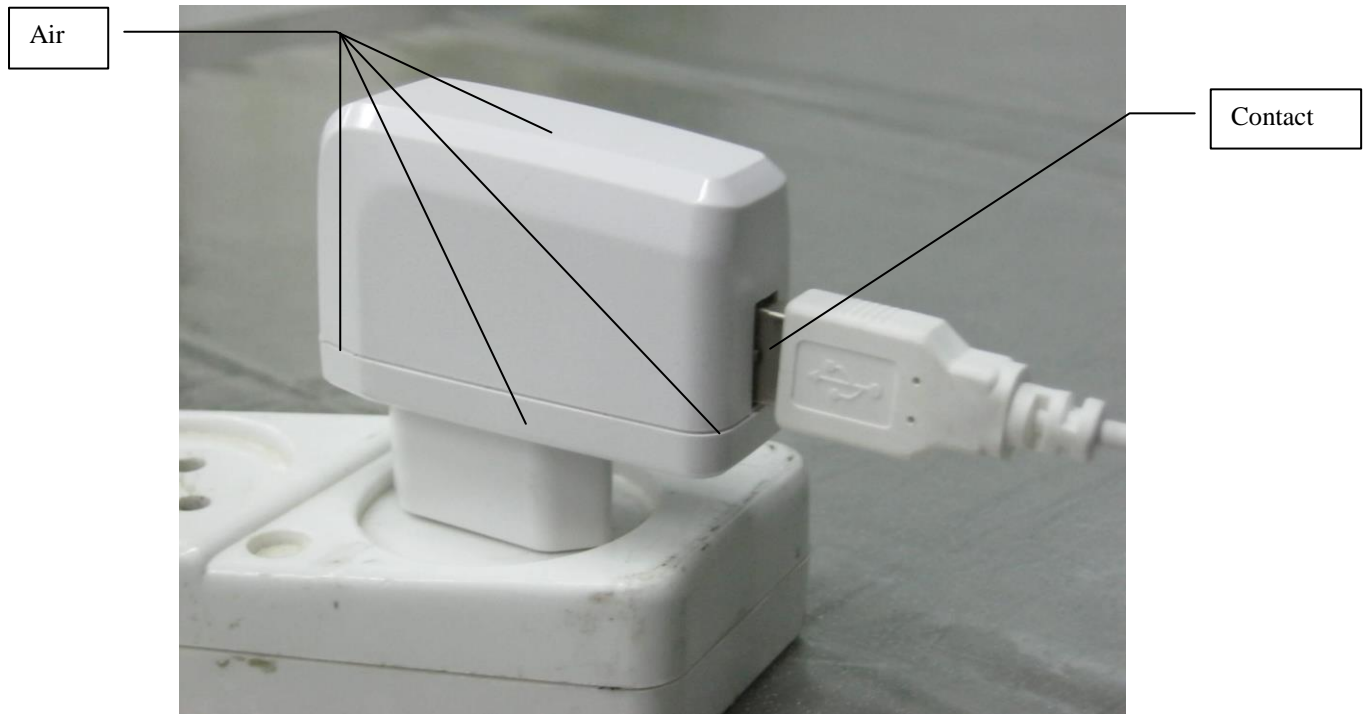

Figure 8. ESD Test Points

Immunity to Electrostatic Discharge

E.U.T Description 2G Self-powered Smart Hub
Type CelloTrack Nano 20, P/N: GC9770001-000
Serial Number: 982966

Specification: EN 61000-4-2: 2009

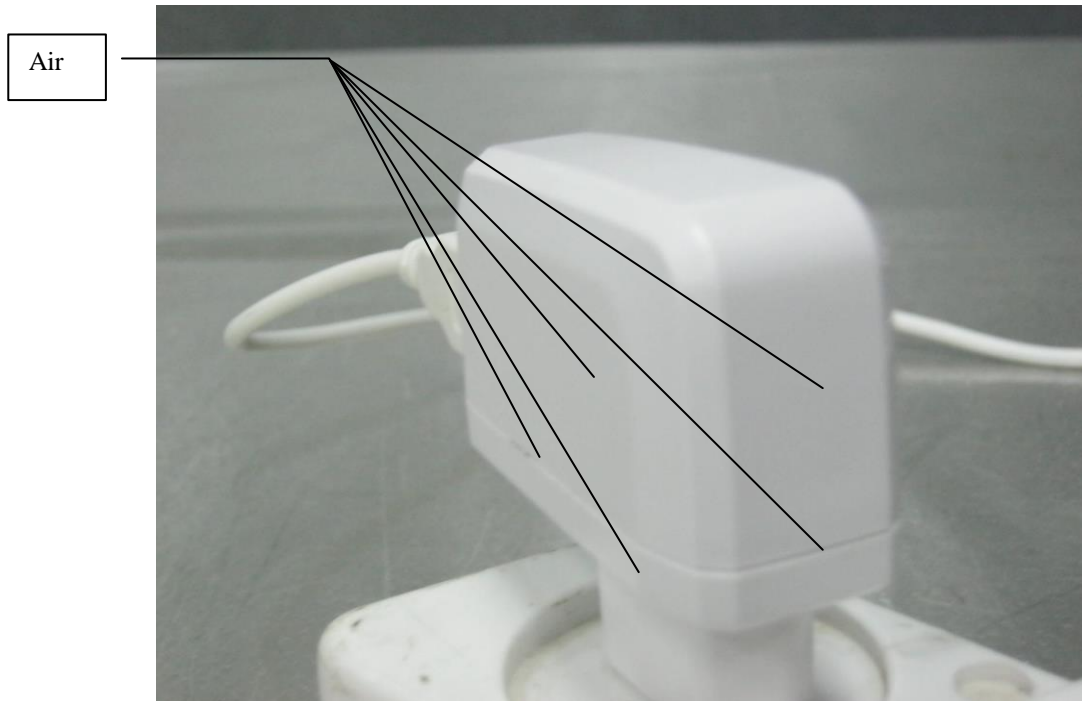

Figure 9. ESD Test Points

Immunity to Electrostatic Discharge

E.U.T Description 2G Self-powered Smart Hub
Type CelloTrack Nano 20, P/N: GC9770001-000
Serial Number: 982966

Specification: EN 61000-4-2: 2009

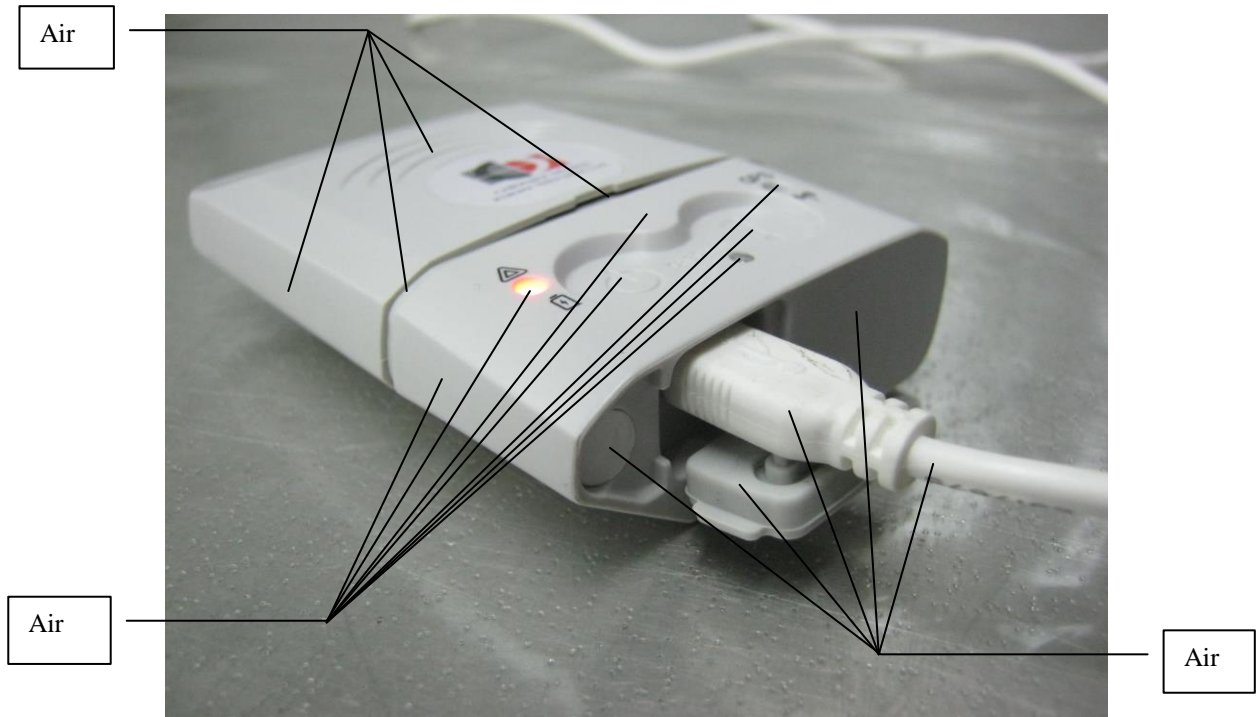

Figure 10. ESD Test Points

Immunity to Electrostatic Discharge

E.U.T Description 2G Self-powered Smart Hub
Type CelloTrack Nano 20, P/N: GC9770001-000
Serial Number: 982966

Specification: EN 61000-4-2: 2009

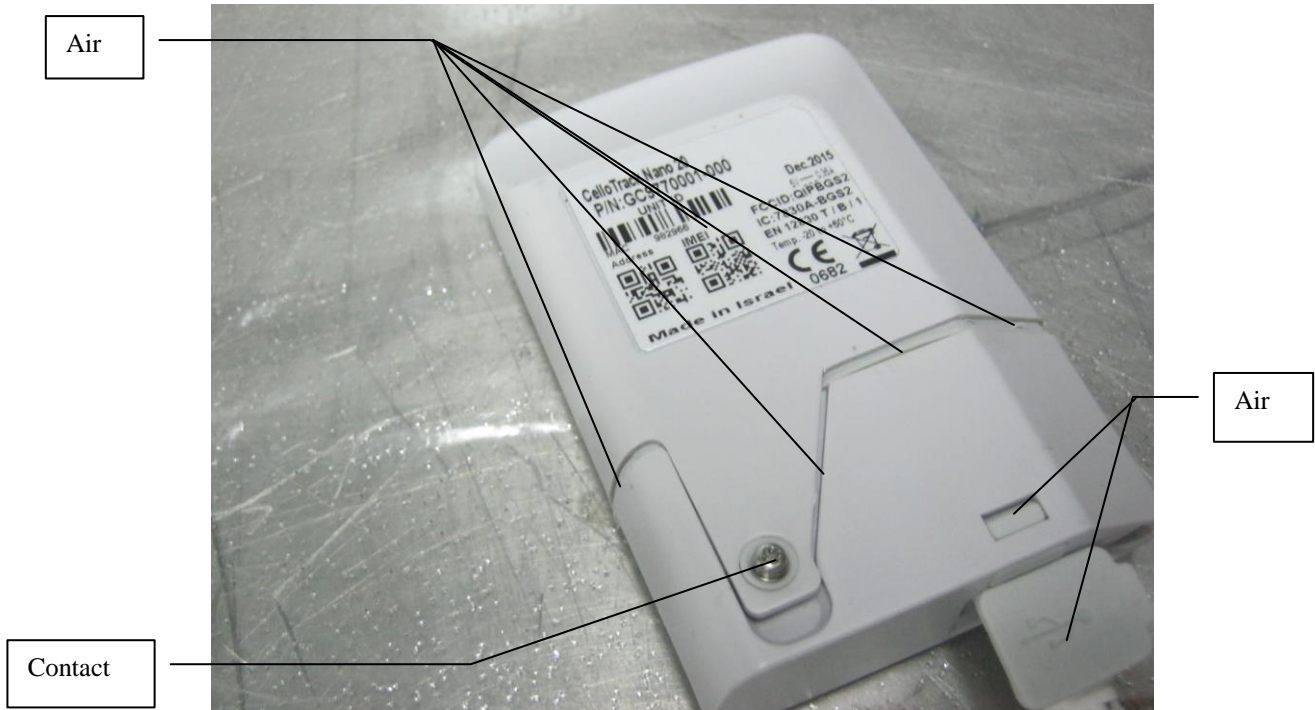

Figure 11. ESD Test Points

Immunity to Electrostatic Discharge

E.U.T Description 2G Self-powered Smart Hub
Type CelloTrack Nano 20, P/N: GC9770001-000
Serial Number: 982966

Specification: EN 61000-4-2: 2009



Figure 12. ESD Test Points

Immunity to Electrostatic Discharge

E.U.T Description Temperature/Humidity Multi-Sensing Device
Type MultiSense TH, P/N: 715-50200
Serial Number: 48.1A.84.00.06.61

Specification: EN 61000-4-2: 2009



Figure 13. ESD Test Points

Immunity to Electrostatic Discharge

E.U.T Description Temperature/Humidity Multi-Sensing Device
Type MultiSense TH, P/N: 715-50200
Serial Number: 48.1A.84.00.06.61

Specification: EN 61000-4-2: 2009



Figure 14. ESD Test Points

Immunity to Electrostatic Discharge

E.U.T Description Temperature/Humidity Multi-Sensing Device
Type MultiSense TH, P/N: 715-50200
Serial Number: 48.1A.84.00.06.61

Specification: EN 61000-4-2: 2009

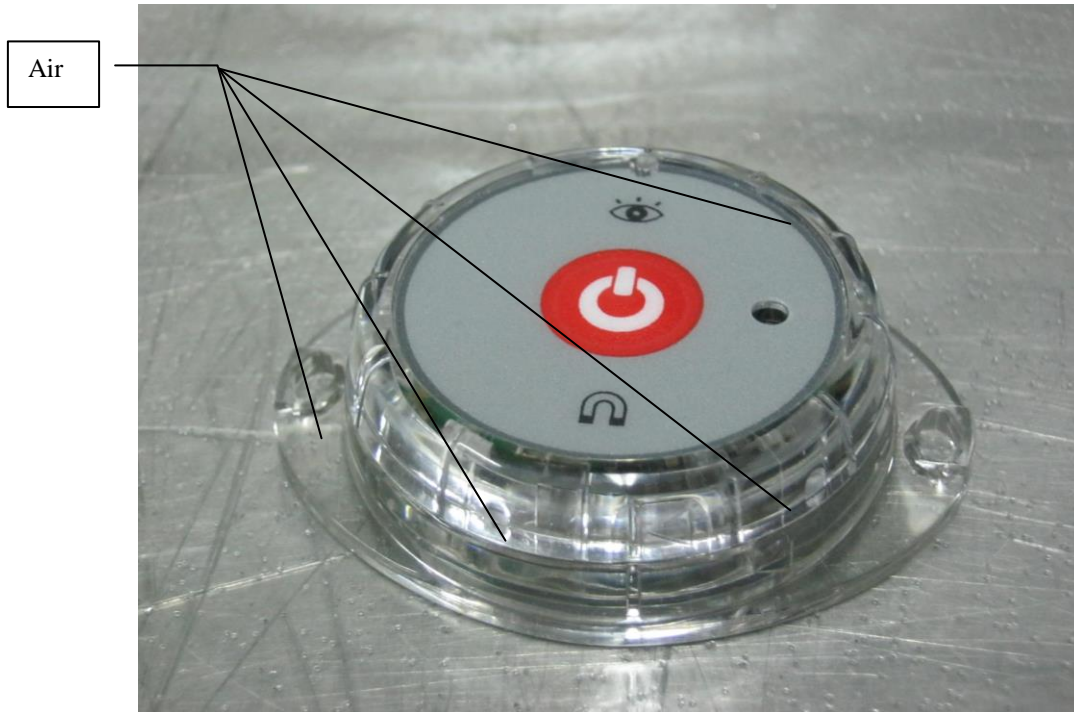

Figure 15. ESD Test Points

Immunity to Electrostatic Discharge

E.U.T Description Muli-Sensing Device
Type MultiSense, P/N: 715-50100
Serial Number: 48.1A.84.00.06.E8

Specification: EN 61000-4-2: 2009

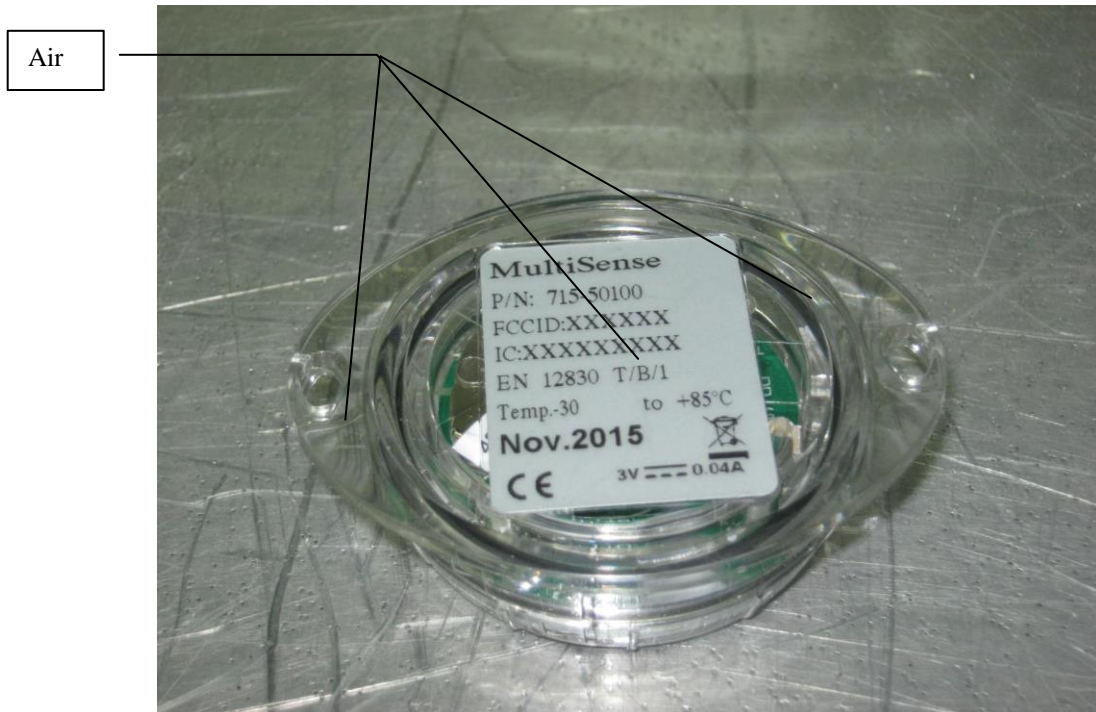

Figure 16. ESD Test Points

Immunity to Electrostatic Discharge

E.U.T Description	Muti-Sensing Device
Type	MultiSense, P/N: 715-50100
Serial Number:	48.1A.84.00.06.E8

Specification: EN 61000-4-2: 2009

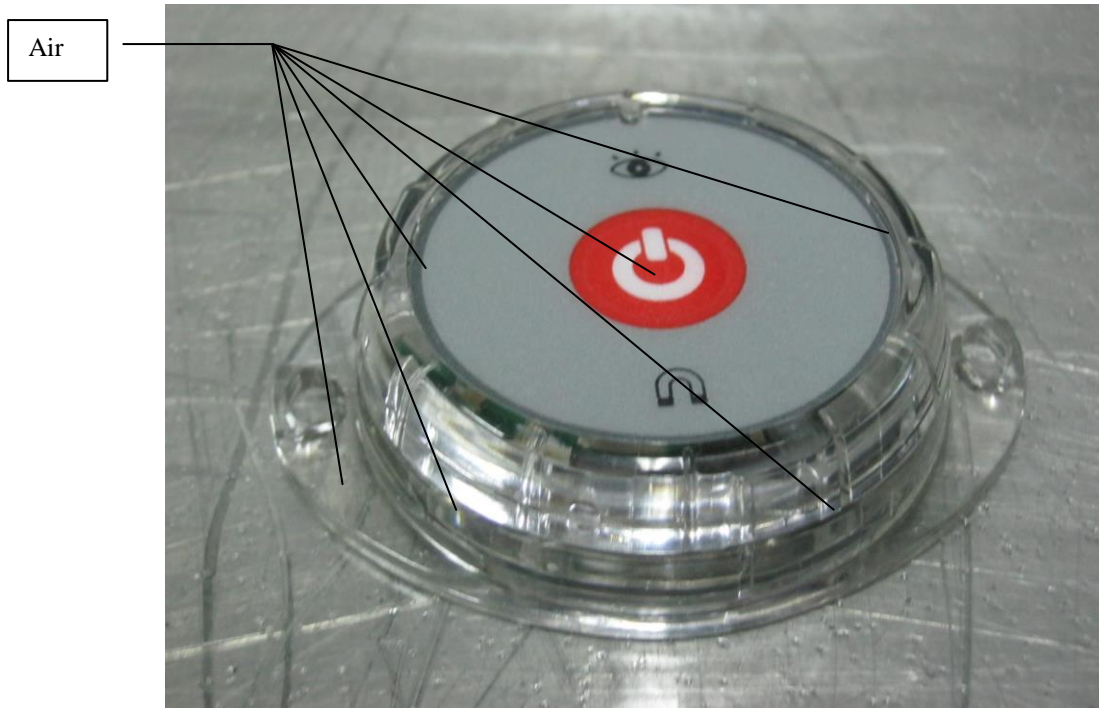

Figure 17. ESD Test Points

Immunity to Electrostatic Discharge

E.U.T Description	Muti-Sensing Device
Type	MultiSense, P/N: 715-50100
Serial Number:	48.1A.84.00.06.E8

Specification: EN 61000-4-2: 2009

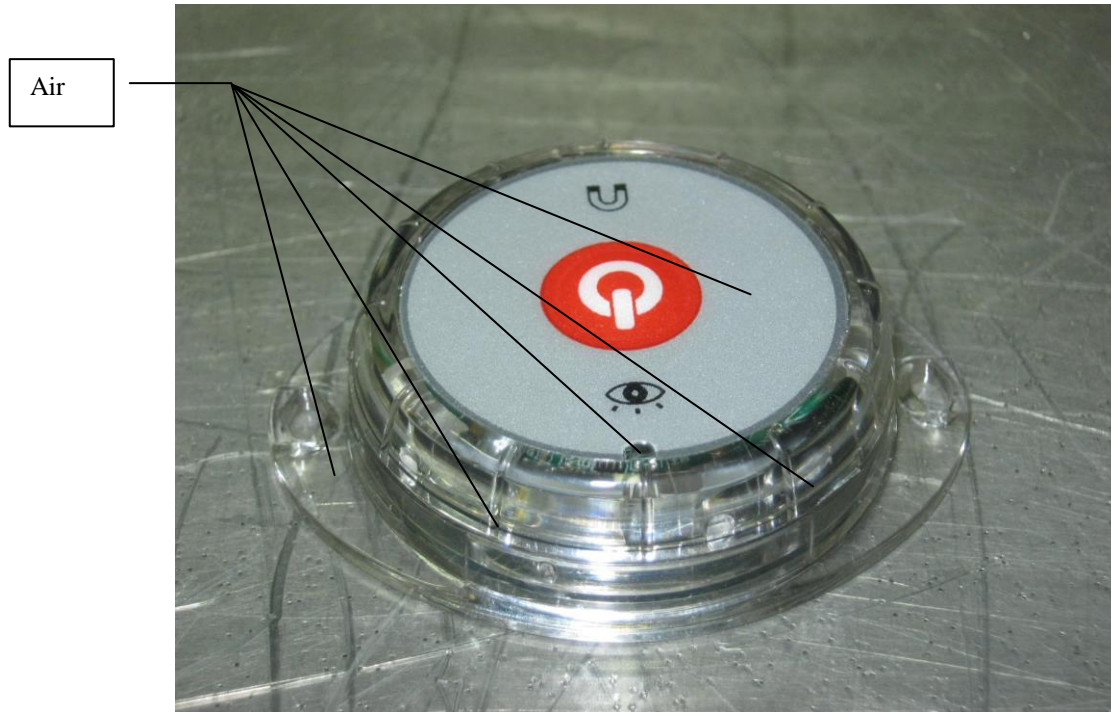

Figure 18. ESD Test Points

12. Immunity to Radiated Field

12.1 Test Specification

EN 61000-4-3: 2006 + Amendments A1: 2008; A2: 2010

12.2 Test Procedure

The E.U.T. was subjected to a field of 3V/m, amplitude modulated 80% by a 1kHz sinusoidal signal.

The Radiated Field was applied in vertical and horizontal polarization using Biconilog Periodical antenna in the frequency range of 80-1000 and horn antennas in the frequency range of 1400 – 2700 MHz.

The Radiated Field was calibrated and tested for uniformity in accordance with Section 6.2 of IEC 61000-4-3.

The calibration values for the driver signal generator were based on the data given in I.T.L. "Radiated Immunity Calibration Test Report" No. PM-112R-IMM.

The frequency was swept using discrete increments having a value less than 1% of the fundamental frequency.

The performance of the E.U.T. was verified during the test as described in Section 7.

The test setup is illustrated in the photograph, *Figure 27. Immunity to Radiated Field Test*.

Note: Opinion and Interpretation:

The most sensitive surface of the E.U.T. was fully tested.

The most sensitive E.U.T. surface was determined as follows:

A preliminary radiated emission test in the frequency range 80 – 1000 MHz was performed inside the semi-anechoic chamber using an E-field probe and spectrum analyzer. The surface having the maximum radiation level was selected as the most sensitive surface.

12.3 Test Results

The E.U.T. passed the Radiated Immunity Tests as required by specifications:

EN 61000-4-3: 2006 + Amendments A1: 2008; A2: 2010.

For additional information see *Figure 19*.



Radiated Immunity

E.U.T Description 2G Self-powered Smart Hub With Multi-Sensing Device and Temperature/Humidity Multi-Sensing Device

Type CelloTrack Nano 20, P/N: GC9770001-000; MultiSense, P/N: 715-50100, MultiSense TH, P/N: 715-50200

Serial Number: 982966, 48.1A.84.00.06.E8, 48.1A.84.00.06.61

Specification: EN 61000-4-3: 2006 + A1: 2008, A2: 2010, 80-1000; 1400-2700 MHz Amplitude Modulation: 80% AM by 1 kHz				
Frequency (MHz)		Antenna Polarity	Specification (V/m)	PASS / FAIL
<u>From</u>	<u>To</u>			
80	1000	Horizontal	3.0	Pass
80	1000	Vertical	3.0	Pass
1400	2700	Horizontal	3.0	Pass
1400	2700	Vertical	3.0	Pass

Figure 19. Immunity to Radiated Field

13. Immunity to Electrical Fast Transient / Burst

13.1 Test Specification

EN 61000-4-4: 2004 + Amendment A1: 2010

13.2 Test Procedure

The E.U.T. was placed 0.1 m above a reference ground plane.

The EFT/B generator was placed on, and grounded to, this ground plane. See the photograph, *Figure 28. Immunity to Electrical Fast Transient / Burst Test*.

A test signal having the waveform described in *Figure 29. Transient Waveforms* was applied to the phase neutral and ground lines of the E.U.T mains input, at a distance of 1 meter from the E.U.T. The test signal voltage was 1 kV and it was applied for 1 minute to each line, in negative and positive polarities.

The same test signal was applied to the signal lines, control and DC lines (as applicable), that are connected to the E.U.T. The voltage level was 0.5 kV in this case. Applicable signal and control lines should have a length greater than 3m.

13.3 Test Results

The E.U.T. passed the immunity to electrical fast transients / bursts requirements as detailed by specification EN 61000-4-4: 2004 + Amendment A1: 2010.

Additional details are given in *Figure 20*.



Electrical Fast Transient / Burst

E.U.T Description 2G Self-powered Smart Hub
Type CelloTrack Nano 20, P/N: GC9770001-000
Serial Number: 982966

Specification: EN 61000-4-4: 2004 + Amendment A1: 2010

Positive Polarity

Negative Polarity

TEST POINT	PASS / FAIL	ANOMALY	SPECIFICATION (kV)
Phase	Pass	No anomaly	1.0
Neutral	Pass	No anomaly	1.0

Figure 20. Immunity to Electrical Fast Transient / Burst

14. Immunity to Conductive Surges

14.1 Test Specification

EN 61000-4-5: 2006

14.2 Test Procedure

The E.U.T. was subjected to surges in the form of double exponential waves as follows:

For AC or DC power lines:

Open circuit voltage: Rise time of 1.2 μ sec. and pulse width of 50 μ sec.

Short circuit current: Rise time of 8 μ sec. and pulse width of 20 μ sec.

See *Figure 30 Open Circuit Voltage Waveform (1.2/50 μ s)* to *Figure 31 Short Circuit Current Waveform (8/20 μ s)*.

For signal/telecommunication lines:

Open circuit voltage: Rise time of 10 μ sec. and pulse width of 700 μ sec.

Short circuit current: Rise time of 5 μ sec. and pulse width of 320 μ sec.

See *Figure 32. Open Circuit Voltage Waveform (10/700 μ s)* to *Figure 33 Short Circuit Current Waveform (5/320 μ s)*.

The surges were applied to the E.U.T. AC power lines in differential mode. The differential (between phase and neutral) voltages were 0.5 and 1 kV.

The surges were injected in both positive and negative polarities in to the AC line, at phase angles of 0°, 90°, 180°, 270° and 360°; both peak and zero crossings.

At least five surges were applied at each polarity. The surge repetition rate was kept to not more than one per minute.

DC power lines were tested at 0.5 kV (when applicable).

The performance of the E.U.T. was verified during the test as described in section 7.

The test setup is shown in the photograph, *Figure 34. Immunity to Conductive Surges*.

14.3 Test Results

The E.U.T. passed the immunity to surges requirements as detailed by specification EN 61000-4-5: 2006.

Additional details are given in Figure 21.



Immunity to Conductive Surges

E.U.T Description 2G Self-powered Smart Hub
Type CelloTrack Nano 20, P/N: GC9770001-000
Serial Number: 982966

Specification: EN 61000-4-5: 2006

TEST POINT	Polarity	0°/360°	90°	180°	270°	Specified Level	Remarks
Phase to Neutral	+	P	P	P	P	0.5, 1 kV	
	-	P	P	P	P	0.5, 1 kV	

Figure 21. Immunity to Conductive Surges

NOTE: Each test was executed at least five times.

15. Immunity to Conducted Disturbances

15.1 Test Specification

EN 61000-4-6: 2009

15.2 Test Procedure

The E.U.T. was subjected to conducted disturbances in the frequency range 0.15 - 80 MHz, 3 VRMS, 1kHz, 80% AM modulation.

The disturbance signal was applied to the AC power lines using a Coupling Decoupling Network (CDN) or RF Current Injection Probe for Signal Lines.

The driver signal generator levels used are based on calibration that was performed in accordance with Section 6.4 and Annex A of EN61000-4-6, I.T.L. Procedures PM-111-CDN/M and PM-111-C.P. 105.

The frequency was swept using discrete increments having a value less than 1% of the fundamental frequency.

The performance of the E.U.T. was verified during the test as described in Section 7.

The test setup is illustrated in the photograph *Figure 35. Conducted Disturbances*.

15.3 Test Results

The E.U.T. passed the Conducted Disturbances immunity tests as required by specification EN 61000-4-6: 2009.

Additional details are given in *Figure 22*.



Immunity to Conducted Disturbances

E.U.T Description 2G Self-powered Smart Hub
Type CelloTrack Nano 20, P/N: GC9770001-000
Serial Number: 982966

Specification: EN 61000-4-6: 2009
Tested at 1 kHz 80% AM Modulation

Using CDN Network

TEST POINT	PASS / FAIL	ANOMALY	SPECIFICATION (VRMS)
AC Power Port (Phase, Neutral)	Pass	No anomaly	3

Figure 22. Immunity to Conducted Disturbances

16. Voltage Dips and Short Interruptions

16.1 Test Specification

EN 61000-4-11: 2004

16.2 Test Procedure EN 301 489-1

The E.U.T. was operated from 230VAC, 50Hz

The following voltage dips and interruptions were applied:

1. Voltage dip: 0.5 cycles, reduction of 100% of U_t (rated voltage)
2. Voltage dip: 1 cycle, reduction of 100% of U_t .
3. Voltage dip: 25 cycles, reduction of 30% of U_t .
4. Voltage interruption: 250 cycles, reduction of 100% of U_t .

Each test was carried out 3 times, using equipment and test methods prescribed in EN 61000-4-11: 2004

16.3 Test Procedure EN 301 489-3

The E.U.T. was operated from 230VAC, 50Hz

The following voltage dips and interruptions were applied:

1. Voltage dip: 10 msec., reduction of 30% of U_t (rated voltage)
2. Voltage dip: 100 msec, reduction of 60% of U_t .
3. Voltage interruption: 5000 msec, reduction of >95% of U_t .

Each test was carried out 3 times, using equipment and test methods prescribed in EN 61000-4-11: 2004

The test setup is shown in the photograph, *Figure 36. Voltage Dips and Short Interruptions.*

16.4 Test Results

The E.U.T. passed the immunity to voltage dips and short interruptions requirements as detailed by specification EN 61000-4-11: 2004.

17. Set Up Photographs



Figure 23. Conducted Emission From AC Mains Test



Figure 24. Radiated Emission Test



Figure 25 Voltage Fluctuations Test

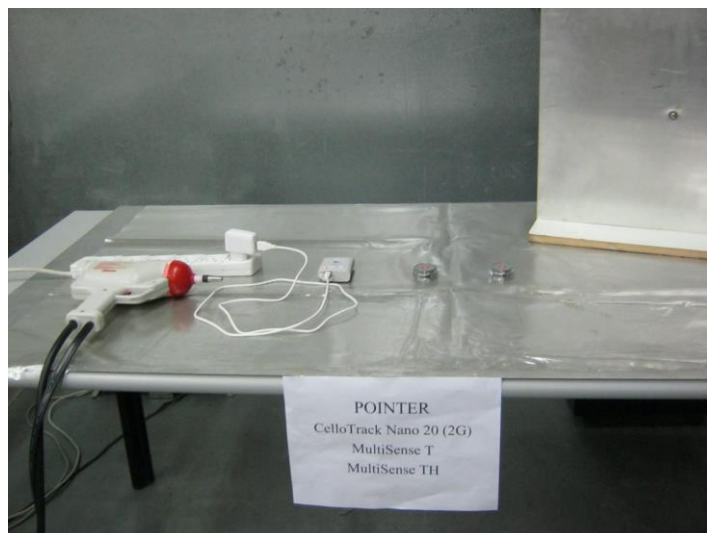

Figure 26. Immunity to Electrostatic Discharge Test



Figure 27. Immunity to Radiated Field Test



Figure 28. Immunity to Electrical Fast Transient / Burst Test

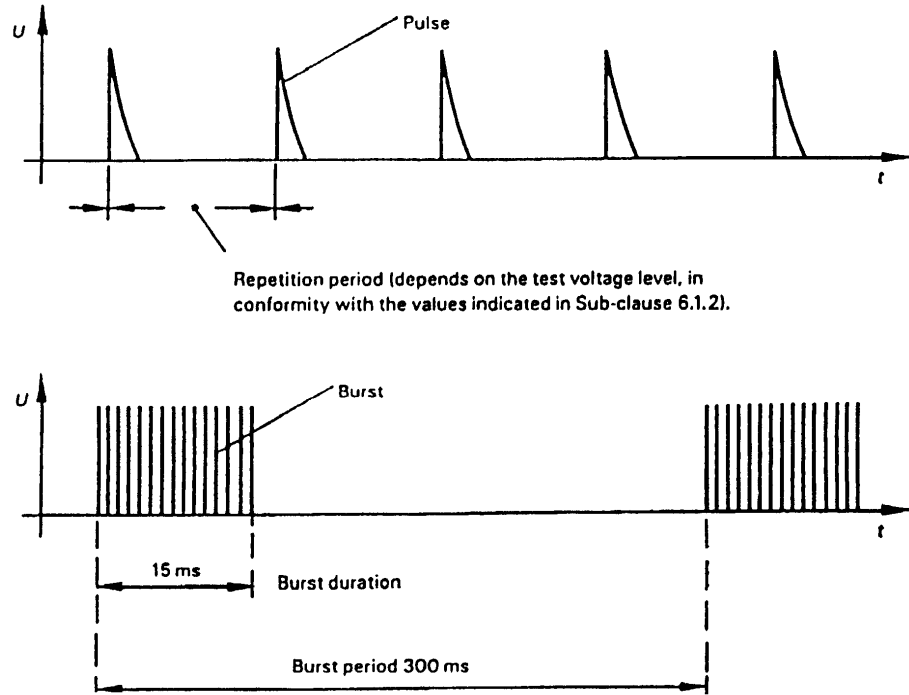
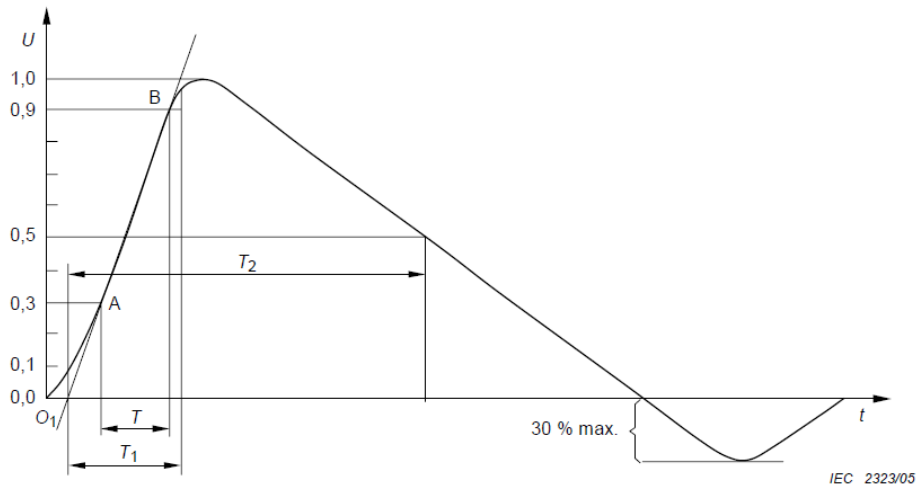
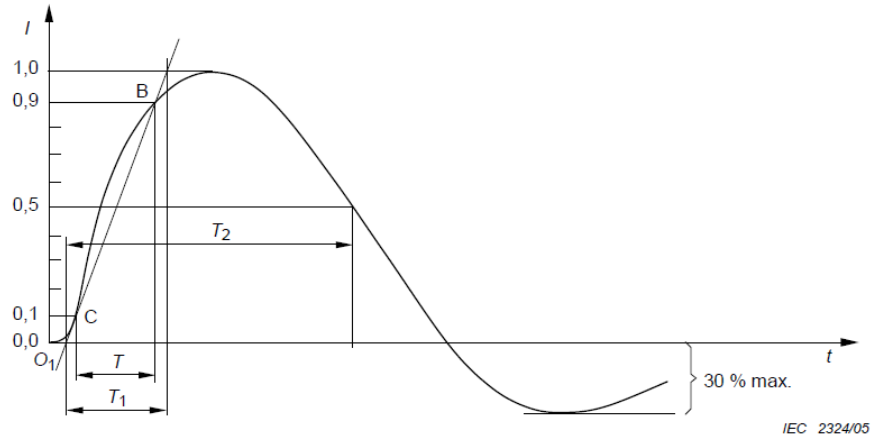

Figure 29. Transient Waveforms



Front time: $T_1 = 1,67 \times T = 1,2 \mu s \pm 30 \%$
 Time to half-value: $T_2 = 50 \mu s \pm 20 \%$

Figure 30 Open Circuit Voltage Waveform (1.2/50 μs)



Front time: $T_1 = 1,25 \times T = 8 \mu s \pm 20 \%$
Time to half-value: $T_2 = 20 \mu s \pm 20 \%$

Figure 31 Short Circuit Current Waveform (8/20 μs)

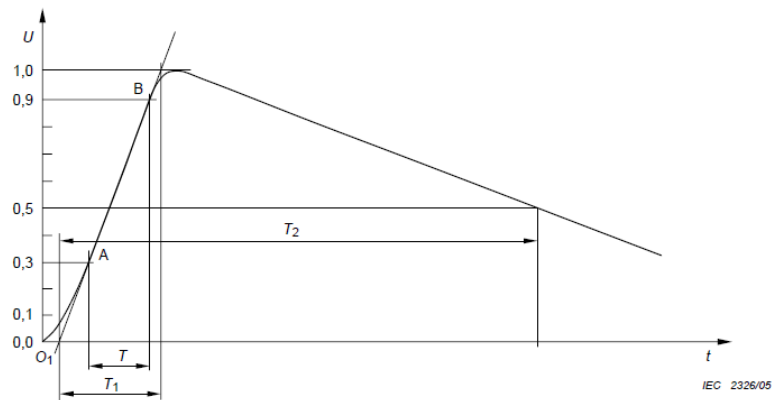

Front time: $T_1 = 1,67 \times T = 10 \mu s \pm 30 \%$
Time to half-value: $T_2 = 700 \mu s \pm 20 \%$

Figure 32. Open Circuit Voltage Waveform (10/700μs)

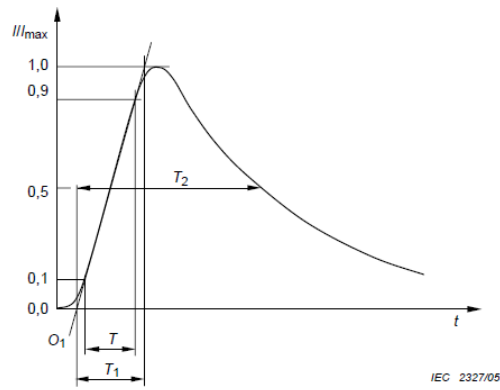

Front time: $T_1 = 1,25 \times T = 5 \mu\text{s} \pm 20 \%$
 Time to half-value: $T_2 = 320 \mu\text{s} \pm 20 \%$.

Figure 33 Short Circuit Current Waveform (5/320µs)



Figure 34. Immunity to Conductive Surges

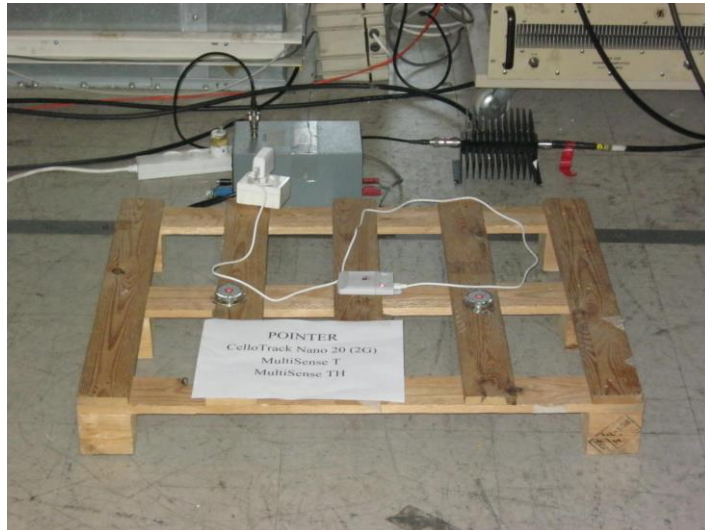











Figure 35. Conducted Disturbances





Figure 36. Voltage Dips and Short Interruptions

18. Signatures of the E.U.T's Test Engineers

Test	Test Engineer Name	Signature
Conducted Emissions From AC Mains	Y. Mordukhovitch	
Conducted Emissions From Telecom Ports	Y. Mordukhovitch	
Radiated Emissions	Y. Mordukhovitch	
Harmonics Emissions	Y. Mordukhovitch	
Voltage Fluctuations	Y. Mordukhovitch	
ESD	Y. Mordukhovitch	
Radiated Immunity	Y. Mordukhovitch	
EFT/B	Y. Mordukhovitch	
Conductive Surges	Y. Mordukhovitch	



Test	Test Engineer Name	Signature
Conducted Disturbances	Y. Mordukhovitch	
Voltage Dips and Short Interruptions	Y. Mordukhovitch	

19. APPENDIX A - CORRECTION FACTORS

19.1 Correction factors for

CABLE

from EMI receiver
to test antenna
at 3 meter range.

Frequency (MHz)	Cable Loss (dB)
0.010	0.4
0.015	0.2
0.020	0.2
0.030	0.3
0.050	0.3
0.075	0.3
0.100	0.2
0.150	0.2
0.200	0.3
0.500	0.4
1.00	0.4
1.50	0.5
2.00	0.5
5.00	0.6
10.00	0.8
15.00	0.9
20.00	0.8

Frequency (MHz)	Cable Loss (dB)
50.00	1.2
100.00	0.7
150.00	20.1
200.00	2.3
300.00	2.9
500.00	3.8
750.00	4.8
1000.00	5.4
1500.00	6.7
2000.00	9.0
2500.00	9.4
3000.00	9.9
3500.00	10.2
4000.00	11.2
4500.00	12.1
5000.00	13.1
5500.00	13.5
6000.00	14.5

NOTES:

1. The cable type is SPUMA400 RF-11N(X2) and 39m long
2. The cable is manufactured by Huber + Suhner



19.2 Correction factors for

Biconical antenna

Model: 3104

Antenna serial number: 2606

3 meter range

FREQUENCY	AFE
(MHz)	(dB/m)
30	12.84
35	12.25
40	11.97
45	11.40
50	11.88
60	11.55
70	9.35
80	7.44
90	11.21
100	11.57
120	13.10
140	12.57
160	14.61
180	16.48
200	15.15



19.3 Correction factors for

Log Periodic ANTENNA

Model: 3146

Antenna serial number: 9505-4081

3 meter range

FREQUENCY	AFE
(MHz)	(dB/m)
200	11.55
250	11.60
300	14.43
400	15.38
500	17.98
600	18.78
700	21.17
800	21.16
900	22.67
1000	24.09



20. APPENDIX B - MEASUREMENT UNCERTAINTY

Test Method	Expanded Uncertainty (95% Confidence K=2)
Conducted Emission (EN 55011/CISPR11,EN55022/CISPR 22, ANSI C63.4)	± 3.44 dB
Radiated Emission (EN 55011/CISPR11,EN55022/CISPR 22, ANSI C63.4)	± 4.98 dB
ESD (EN/IEC 61000-4-2)	± 10 %
Radiated Immunity (EN/IEC 61000-4-3)	± 2.2 dB
EFT/B (EN/IEC 61000-4-4)	± 10 %
Conductive Surges (EN/IEC 61000-4-5)	± 9 %
Conducted RF Disturbances (EN/IEC 61000-4-6)	± 2.4 dB
Voltage Dips and Short Interruptions EN/IEC 61000-4-11)	± 6 %